

*TB 9-4931-537-35

DEPARTMENT OF THE ARMY TECHNICAL BULLETIN

CALIBRATION PROCEDURE FOR CROSS-CHECKS, INTERCOMPARISONS, AND VISUAL INSPECTIONS

Headquarters, Department of the Army, Washington, DC
2 May 2002

Approved for public release; distribution is unlimited.

REPORTING OF ERRORS AND RECOMMENDING IMPROVEMENTS

You can help improve this publication. If you find any mistakes or if you know of a way to improve the procedure, please let us know. Mail your letter or DA Form 2028 to: Commander, U. S. Army Aviation and Missile Command, ATTN: AMSAM-MMC-MA-NP, Redstone Arsenal, AL 35898-5230. A reply will be furnished to you. You may also send in your comments electronically to our e-mail address: 2028@redstone.army.mil, or FAX 256-842-6546/DSN 788-6546. Instructions for sending an electronic 2028 may be found at the back of this procedure.

SECTION		Paragraph	Page
	I. GENERAL		
	Purpose	1	2
	Applicability.....	2	2
	Definitions.....	3	2
	Policy	4	2
	II. CROSS-CHECKS		
	Purpose	5	3
	Applicability.....	6	3
	Policy	7	3
	Equipment to be cross-checked.....	8	4
	Discussion	9	4
	Reports.....	10	5
	Cross-check procedures	11	5
	III. VISUAL INSPECTIONS AND INTERCOMPARISONS		
	Purpose	12	12
	Applicability.....	13	12
	Policy	14	12

**SECTION I
GENERAL**

1. Purpose. This bulletin provides guidance and procedures applicable to the cross-checks, intercomparisons, and visual inspections of measurement standards.

2. Applicability. This bulletin is applicable to all TMDE support activities (TSA), Army National Guard (ARNG), and Government owned contractor operated facilities (GOCO), except the U.S. Army Primary Standards Laboratory (APSL).

3. Definitions

a. Cross-check. A secondary transfer level functional comparison between selected measurement standards to verify that no significant departure from assigned tolerances has occurred.

b. Intercomparison. A secondary reference level functional comparison, or operational check, between measurement standards to verify that no significant departure from assigned tolerances has occurred.

c. Visual Inspection. The physical inspection of a measurement standard for apparent damage.

4. Policy

a. Cross-checks will be performed on designated transfer level measurement standards, or equivalents, to verify the standards have not been damaged or accuracy degraded during shipment and/or to prevent out-of-tolerance standards from being used to perform calibrations.

b. Intercomparison checks will be performed by all reference level activities and activities with reference level or higher capabilities. The intercomparison check is required on reference level measurement standards being calibrated by the equipment manufacturer or higher calibration activity. All items in the APSL Exchange Package (APSLEP) will be intercompared and documented. This intercomparison will encompass enough cardinal points to convince the person performing the intercomparison that the item meets all required specifications.

c. A visual inspection will be performed on measurement standards that are received from another calibration activity not located in the same building. These inspections are performed to assure that standards have not been damaged or degraded during transportation.

**SECTION II
CROSS-CHECKS**

5. Purpose. This section provides guidance and procedures applicable to the cross-check of measurement standards.

6. Applicability. This section is applicable to all transfer level support activities, GOCO facilities, and ARNG.

7. Policy

a. Activities that operate in a fixed configuration (those that do not travel to customer sites) will perform cross-checks on designated measurement standards which are supported by another activity. Cross-checks will be performed at receipt of equipment prior to placing the standard into service, at midcycle (± 10 days), and prior to submitting the standard for re-calibration.

b. Mobile activities that travel to customer sites will perform cross-checks on designated measurement standards which are supported by another activity. The standards will be cross-checked when the activity arrives at the first location where calibration is to be performed (prior to performing the first calibration). Every 28 days (± 3 days) after the first cross-check, and after completing the last calibration prior to departing the last supported unit before submitting the standards for recertification. Activities that move from one location to another on the same installation will perform cross-checks in the same manner as a fixed site.

c. Additional cross-checks will be performed when any indication of problems create doubt of the credibility of measurements, or at any time the accuracy of a measurement is suspect.

d. Cross-check requirements are not justification for the acquisition of additional standards.

e. The TSA collocated in the same building as their Army Calibration Laboratory (ACL), are granted a waiver eliminating the requirement for the TSA to perform cross-checks on their standards when they are received from the ACL and prior to submitting them for re-calibration. However, at midcycle (± 10 days) cross-checks must be performed on the standards. Whenever the ACL calibrates a standard and finds an out-of-tolerance condition, this must be reported to the TSA to enable them to perform actions specified in paragraph **9c** below.

8. Equipment to be Cross-Checked

a. Standards requiring periodic cross-checks are: Calibrator, John Fluke, Model 5700A/(); Amplifier, John Fluke, Model 5725A/(); and Multimeter, Hewlett Packard, Model 3458A/(). These standards are also listed at the top of table 1. Additionally, the organizational chief is responsible for maintaining and assuring all calibration standards and equipment are in proper calibration and operating condition. Therefore, the chief may cross-check additional standards deemed necessary.

b. If an organization does not possess specific items of equipment, listed in **a** above, the most accurate dc voltage, ac voltage, and resistance standards which receive support by a higher level calibration activity, will be cross-checked.

c. When equivalent standards are used in lieu of those listed in table 1, the organizational chief will develop a cross-check similar to the one specified for the standard being replaced. This locally developed cross-check will be included in the cross-check record files.

9. Discussion

a. The ranges and parameters listed in table 1 have been determined to be adequate to provide a reasonable check of the standards while at the same time causing a minimum loss of productive calibration/repair time. The limits assigned are the square root of the sum of the squares. The tolerances used for each standard were obtained from the technical bulletin for the standard.

b. Table 1 has sufficient space for five consecutive cross-checks. Enter data legibly, in blue or black ink, and show all significant digits of the required reading.

c. If a specific standard fails a cross-check, the organizational chief will determine the action to be taken and document the decision. The action taken must ensure that all TMDE calibrated with the failed standard are operating in accordance with the approved calibration procedure. When re-calibration of the TMDE is the course of action, the TMDE owner will be notified and will determine whether or not re-calibration is actually necessary (based on usage of the instrument). If re-calibration is necessary, a mutually agreeable schedule will be established to recalibrate the affected TMDE.

d. Documentation of corrective actions taken will be recorded when a standard fails a cross-check. Documentation may be in the form of notations and explanations in the cross-check table, where possible, or on separate pages attached to the table. Documentation must be in sufficient detail so that an audit trail can confirm that no TMDE had been adversely affected.

e. When a standard fails a cross-check and is determined to be unserviceable, the cross-check readings must be recorded in appropriate table. The only exception permitted is when the standard is inoperative. In such cases the designator INOP. will be placed in the space provided for the cross-check readings, and an explanation noted at the foot or back of cross-check table.

f. When a standard fails between required cross-checks, an entry will be made in the next available column of the table, with the date of failure discovery and actions taken in accordance with **d** and **e** above.

g. At the completion of the calibration loop the organizational chief will ensure that all cross-check records are reviewed and any required corrective action is accomplished. Cross-check records must be retained for at least 2 years and then may be destroyed. Upon request, a copy of the records will be forwarded to USATA.

10. Reports. Cross-check tables will be reproduced locally. All results of cross-checks must be recorded in appropriate table and signed as listed in table. Inclusive dates may be annotated on a single line if a cross-check takes more than 1 day.

SECTION II CROSS-CHECK DATA

11. Cross-Check Procedures

a. Ensure amplifier is properly connected to calibrator.

b. Set **POWER** switches to **ON** and allow at least 4 hours warm up for multimeter and 30 minutes warm up for amplifier and calibrator.

WARNING

The calibrator/amplifier is capable of supplying lethal voltages. Do not make connections to the output terminals when any voltage is present. Placing the calibrator in **STANDBY** may not be enough to avoid shock hazard, since the **OPR/STBY** pushbutton could be pressed accidentally. Press the **RESET** pushbutton and verify that **STANDBY** is lit before making connections to **OUTPUT** terminals.

c. Equipment Setup

(1) With nothing connected to **Input** terminals, perform **ACAL ALL** function on multimeter by pressing **Auto Cal** β (until **ALL** appears) ,, **3**, **4**, **5**, **8** and **ENTER** pushbuttons

TB 9-4931-537-35

(2) This function takes approximately 13 minutes to run. While waiting, and with nothing connected to **Output** terminals, perform **DC Zero** adjustment on calibrator by pressing **Setup Menus**, **Cal**, and **Zero** softkeys

d. Dc Voltage. Calibrator, John Fluke, Model 5700A/() and Multimeter, Hewlett Packard, Model 3458A.

(1) Connect equipment as shown in figure 1.

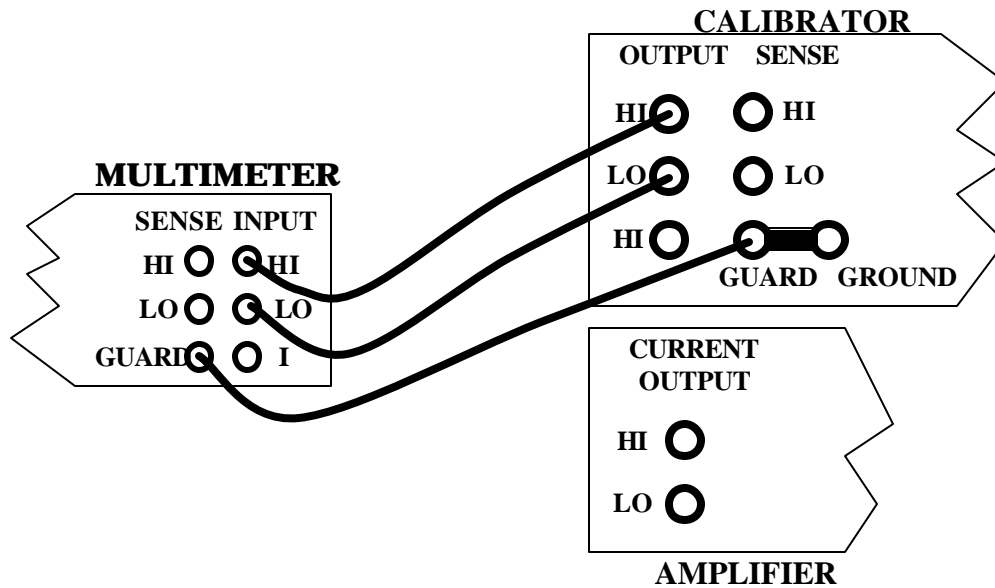

Figure 1. Dc and ac voltage.

(2) Set multimeter **Guard** switch to **Open**. Configure multimeter **NDIG** to **8** (8½ digit display) by pressing the following pushbuttons: **FUNCTION/RANGE**, blue colored key, **MENU N**, then **NUMERIC/USER 8** followed by **Enter**.

(3) Configure multimeter **NPLC** to **100** (100 power line cycles) by pressing the following pushbuttons: **MENU NPLC** then **NUMERIC/USER 1, 0, 0**, followed by **Enter**.

(4) Set calibrator to **(m)V dc** outputs listed in table 1. Record multimeter indications in space produced.

NOTE

The values listed in table 1, Limits (V) column, are calculated for maximum resolution of appropriate range, for example a 100 mV input should be read on multimeter 100 mV range. The first measurement for each perimeter may not auto range properly. If this occurs set multimeter to appropriate range, then set back to auto range.

(5) Set calibrator to **STANDBY**, then press **RESET** pushbutton.

e. Ac Voltage. Calibrator, John Fluke, Model 5700A/() Multimeter, Hewlett Packard, Model 3458A; and Amplifier, John Fluke, Model 5725A/().

CAUTION

3458A maximum input: 707 V rms

(1) Press multimeter **FUNCTION/RANGE ACV** pushbutton; then set calibrator to **(m)V**, **(k)Hz** outputs listed in table 1. Record multimeter indications in space provided.

(2) Set calibrator to **STANDBY**, then press **RESET** pushbutton.

f. Dc Current. Calibrator, John Fluke, Model 5700-A/(), Multimeter, Hewlett Packard, Model 3458A and Amplifier, John Fluke, Model 5725A/().

(1) Connect equipment as shown in figure 2.

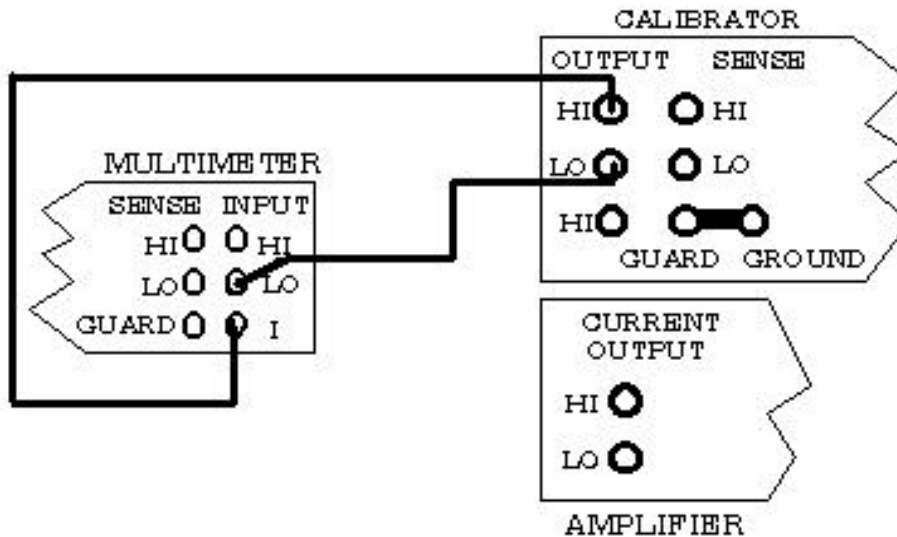

Figure 2. Dc and ac current.

TB 9-4931-537-35

(2) Press multimeter **FUNCTION/RANGE DCI** pushbutton and set **Guard** switch to **To LO** (depressed position).

(3) Preset (in standby mode) calibrator for a 100 μ A output. Press **Currnt Output** softkey until "**Currnt Output NORMAL**" is displayed.

(4) Set calibrator to **Operate**. Record multimeter indications in space provided.

(5) Set calibrator to remaining (m) A dc outputs listed in table 1. Record multimeter indications in space provided.

(6) Set calibrator to **STANDBY**, then press **RESET** pushbutton.

g. Ac Current. Calibrator, John Fluke, Model 5700A/(), Multimeter, Hewlett Packard, Model 3458A and Amplifier, John Fluke, Model 5725A/().

(1) Press multimeter **FUNCTION/RANGE ACI** pushbutton.

(2) Set calibrator to (m, m) A, (k)Hz outputs listed in table 1. Record multimeter indications in space provided.

(3) Set calibrator to **STANDBY**, then press **RESET** pushbutton.

h. Resistance: Calibrator, John Fluke, Model 5700A/(), and Hewlett Packard, Model 3458A.

(1) Connect equipment as shown in figure 3. Set multimeter **Guard** switch to **Open**.

(2) Set multimeter for 4-wire resistance measurements by pressing: **FUNCTION/RANGE** blue colored pushbutton then the **OHM/OHMF** pushbutton. Set **O Comp** to **ON** by pressing **MENU Offset Comp** W pushbutton, followed by **NUMERIC/USER 1** and **Enter** pushbuttons.

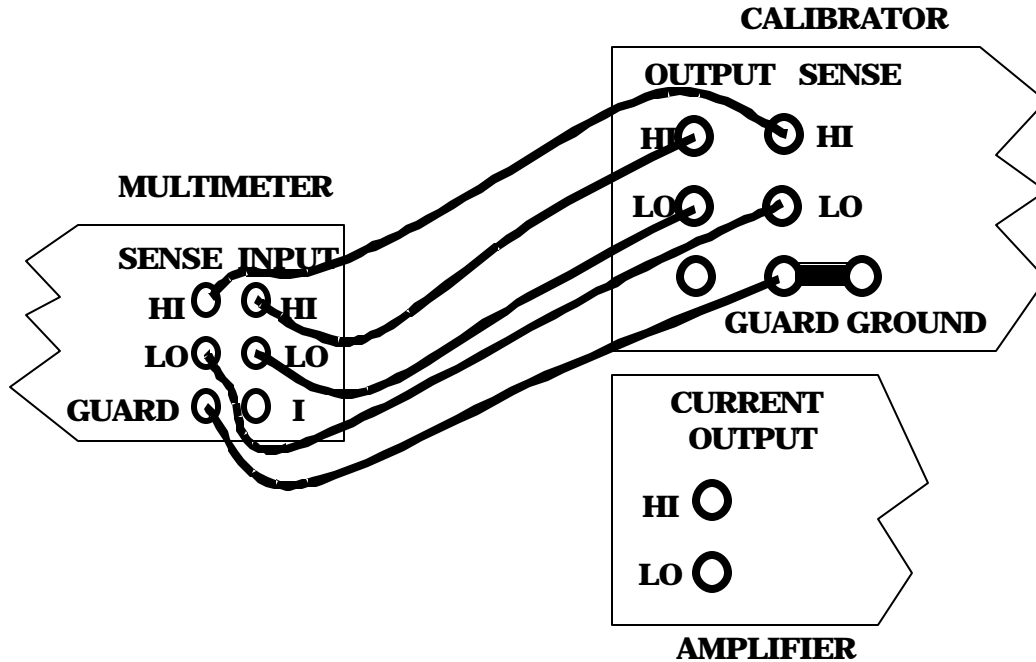

Figure 3. Resistance.

(3) Set calibrator for a **0 W** output. Set calibrator's **EX SENS** to on (illuminated). Set **2 Wire Comp** softkey to **OFF**.

(4) Multimeter indication will be 00.00000 (± 8 digits). Record indication in table 1.

(5) Set calibrator to (**k, M**) W outputs listed in table 1. At each resistance output, adjust the calibrator output adjustment control knob for a calibrator control display reading equal to multimeter indication. The calibrator control **ERROR** display indication will be within specified limits of table 1. Record calibrator **ERROR** display indication in space provided.

(6) Set calibrator to **STANDBY**, then press **RESET** pushbutton.

TB 9-4931-537-35

Table 1. Cross-Check Limits

Calibrator, SN:_____	John	Fluke,	Model	5700A/()	Team: _____		
Amplifier, SN:_____	John	Fluke,	Model	5725A/()	Team	Chief	Name: _____
Multimeter, SN:_____	Hewlett	Packard,	Model	3458A/()	Signature: _____		
Calibrator Output	Limits (V)		Multimeter Indications				
	Min	Max					
100 mV dc	099.99730 mV	100.00270 mV					
1.0 V dc	0.99998560	1.00001440					
10.0 V dc	09.9998670	10.0001330					
100 V dc	099.998410	100.001590					
1000 V dc	0999.97495	1000.02505					
10 mV, 1 kHz	09.97210 mV	10.02790 mV					
100 mV, 10 kHz	099.9634 mV	100.0366 mV					
1.0 V, 50 kHz	0.998093	1.001907					
10 V, 20 Hz	09.98287	10.01713					
10 V, 20 kHz	09.99686	10.00314					
100 V, 100 Hz	099.9588	100.0412					
500 V, 500 Hz	0499.498	500.502					
500 V, 10 kHz ¹	0499.492	500.508					
100 μA dc	099.97900 μA	100.02100 μA					
100 mA dc	099.99318 mA	100.00682 mA					
1.0 A dc	0.9998228 A	1.0001772 A					
1.0 A dc ^{1,2,3}	0.9991507 A	1.0008493 A					
100 μA, 40 Hz	099.8240 μA	100.1760 μA					
100 mA, 5 kHz	099.8338 mA	100.1662 mA					
1.0 A, 500 Hz	0.998563 A	1.001437 A					
1.0 A, 500 Hz ^{1,2}	0.9986403 A	1.0013598 A					
	Error Limits (±)		Calibrator Error Indications				
0.0 Ω	00.00000 (± 8 digits)						
1.0 Ω	0.0135%	135 ppm					
100 Ω	0.0029%	29 ppm					
10 kΩ	0.0020%	20 ppm					

Table 1. Cross-Check Limits - Continued

Calibrator, SN: _____ Amplifier, SN: _____ Multimeter, SN: _____	John John Hewlett	Fluke, Fluke, Packard,	Model Model Model	5700A/() 5725A/() 3458A/()	Team: _____ Team _____ Signature: _____	Chief Name: _____
Calibrator Output	Limits (V) Min Max		Multimeter Indications			
	Error Limits (±)		Calibrator Error Indications			
100 kΩ ⁴	0.0021%	21 ppm				
10 MΩ	0.0079%	79 ppm				
Initials of performing technician:						
Date of cross-check:						

¹Omit check if 5725A/() is not being cross-checked.

²Set 5700A OUTPUT to STANDBY. Move connection at 5700A OUTPUT HI and LO terminals to 5725A CURRENT OUTPUT HI and LO terminals. Set calibrator's **BOOST** pushbutton to on (illuminated) for a 5725A/() amplified 1 A output.

³Set 5700A OUTPUT to STANDBY at completion of check. Move connection at 5725A CURRENT OUTPUT HI and LO terminals to 5700A OUTPUT HI and LO terminals.

⁴Set multimeter **OCOMP** to **OFF** by pressing: **Offset Comp W, 0,** and **Enter** pushbuttons.

TB 9-4931-537-35

Table 2. Cross-Check Record

Date Performed	All items in tolerance?		Location	Remarks
	YES	NO (indicate area)		

Team Chief

Team

Date

Transfer Chief

Branch

Date

QA

Date

**SECTION III
VISUAL INSPECTIONS AND INTERCOMPARISONS**

12. Purpose. This section provides guidance and procedures applicable to visual inspections and intercomparisons of measurement standards.

13. Applicability. This section is applicable to TSAs and ARNG that ship, or transport, their measurement standards to another calibration activity, not located in the same building, for calibration support.

14. Policy

a. Visual Inspection

(1) A visual inspection will be performed on measurement standards that are received from another calibration activity. These inspections are performed to assure that standards have not been damaged or degraded during transportation. Visual inspections are required as follows:

(a) All measurement standards will be visually inspected upon return from the supporting calibration activity.

(b) Visual inspections will be sufficient to assure that no physical damage occurred during shipment which would impair operation of the standard or degrade its measurement capabilities. When a visual inspection indicates that a possible out-of-tolerance condition exists, reliability checks will be performed when the capability to make such measurements exists. If the capability does not exist, the item will be returned to the supporting activity.

(c) A check will be made to ensure all labels and forms have been annotated properly.

(2) Records

(a) Data resulting from visual inspections will be recorded on the reverse side of the calibration test report, or in a separate logbook. When a calibration report is not furnished, data will be recorded on a separate record. As a minimum, data will include: date of visual inspection, condition of standard, and initials of person performing inspection. When damage is observed, a short narrative explanation of the damage, suspected cause, and corrective action taken will be recorded.

(b) These records will be retained by the owner of the standards for three consecutive calibrations. Records may be retained for a longer period when required for historical data.

NOTE

The visual inspection data annotated on test reports may be transcribed to a separate log. This would eliminate the need to maintain non-current test reports on file.

b. Intercomparisons

(1) Intercomparison checks will be performed on all reference level measurement standards being calibrated by the equipment manufacturer, the APSL, or any other higher level calibration activity. This requirement includes the Army Primary Standards Laboratory Exchange Package (APSLEP).

(2) When intercomparison of a measurement standard detects a defective standard, the appropriate action(s) should be taken:

(a) Re-verify calculations for control limits.

(b) Determine which standard is defective by intercomparison with a third standard, by direct measurement of the standards, or by other suitable techniques. When it cannot be determined which standard is defective, the problem should be discussed with the supporting calibration activity.

(c) Determine what caused the out-of-CL condition.

(d) Return the defective standard to the supporting calibration activity for repair or re-calibration after the problem has been discussed with them.

(e) For problems that cannot be resolved, or if assistance is necessary, contact Commander, U.S. Army Aviation and Missile Command, ATTN: AMSAM-TMD-EP, Redstone Arsenal, AL 35898-5000.

TB 9-4931-537-35

THESE ARE THE INSTRUCTIONS FOR SENDING AN ELECTRONIC 2028

The following format must be used if submitting an electronic 2028. The subject line must be exactly the same and all fields must be included; however, only the following fields are mandatory: 1, 3, 4, 5, 6, 7, 8, 9, 10, 13, 15, 16, 17, and 27.

From: "Whomever" whomever@avma27.army.mil

To: 2028@redstone.army.mil

Subject: DA Form 2028

1. **From:** Joe Smith
2. **Unit:** Home
3. **Address:** 4300 Park
4. **City:** Hometown
5. **St:** MO
6. **Zip:** 77777
7. **Date Sent:** 19-Oct-93
8. **Pub No:** TB 9-6625-xxxx-35
9. **Pub Title:** Calibration Procedure for ...
10. **Publication Date:**
11. **Change Number:**
12. **Submitted Rank:** MSG
13. **Submitter Fname:** Joe
14. **Submitter Mname:** T
15. **Submitter Lname:** Smith
16. **Submitter Phone:** (123) 123-1234
17. **Problem:** 1
18. **Page:** 2
19. **Paragraph:** 3
20. **Line:** 4
21. **NSN:** 5
22. **Reference:** 6
23. **Figure :** 7
24. **Table:** 8
25. **Item:** 9
26. **Total:** 123
27. **Text:**

This is the text for the problem below line 27.

TB 9-4931-537-35

By Order of the Secretary of the Army:

ERIC K. SHINSEKI
General, United States Army
Chief of Staff

OFFICIAL:

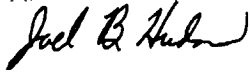

JOEL B. HUDSON
Administrative Assistant to the
Secretary of the Army

0209302

Distribution:

To be distributed in accordance with IDN 344461, requirements for calibration procedure TB 9-4931-537-35.

PIN: 070184-000